

**SAMUEL JACKSON, INC.**

81890 FLOW TOOLS  
EXTERNAL ELECTRICAL  
CONNECTIONS

CA20300B  
8-09

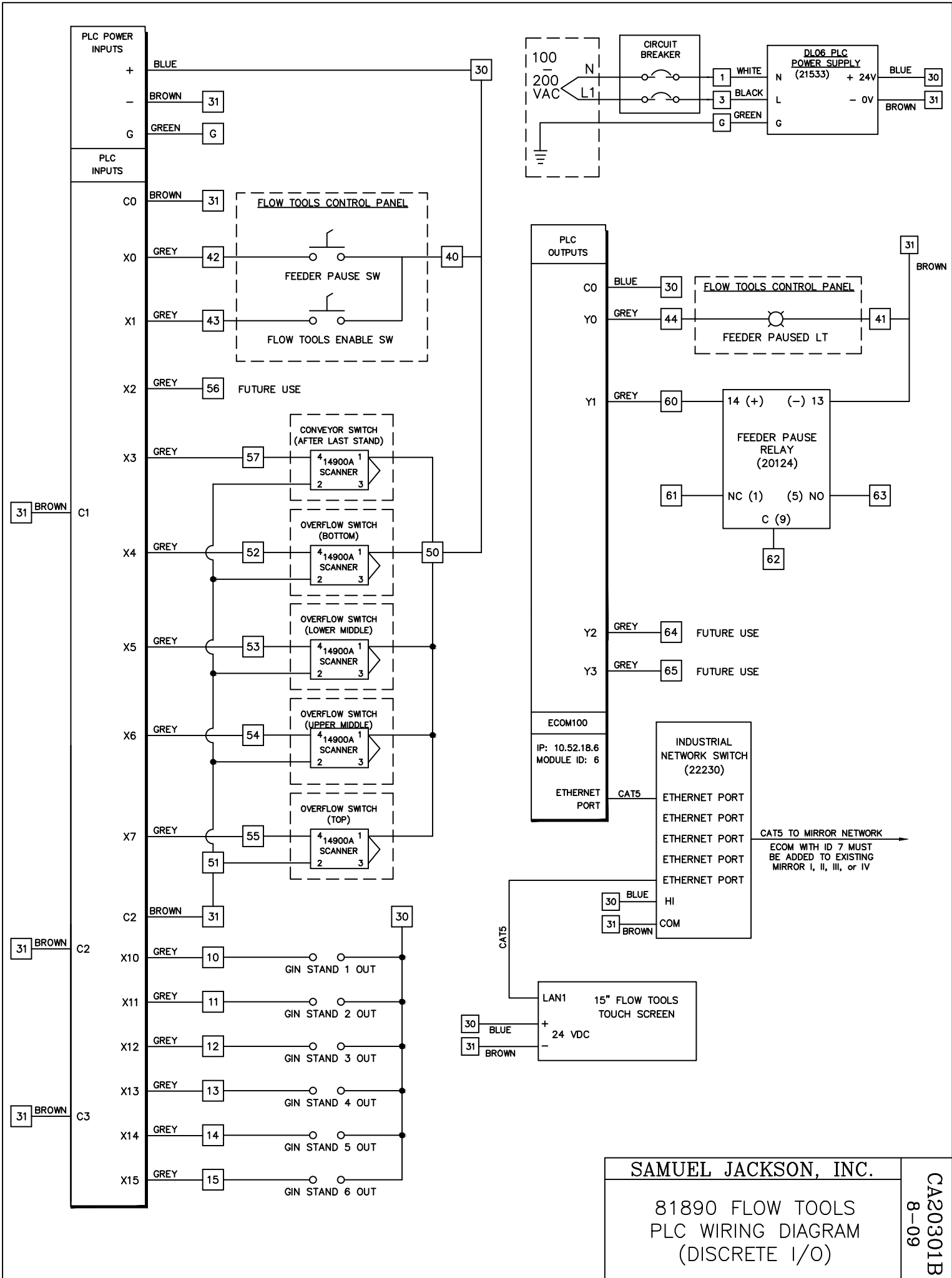

**SAMUEL JACKSON, INC.**

81890 FLOW TOOLS  
PLC WIRING DIAGRAM  
(DISCRETE I/O)

CA20301B  
8-09

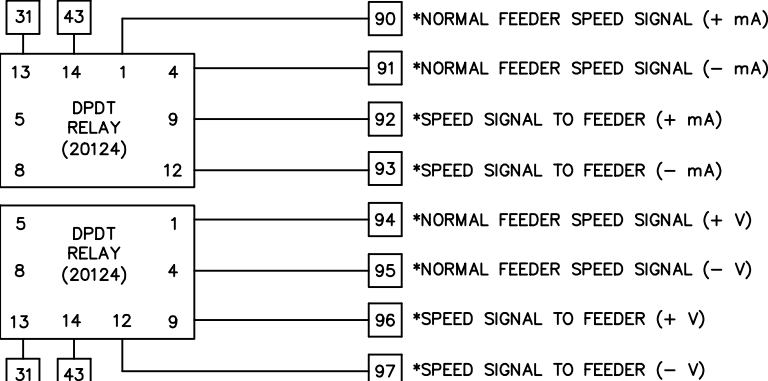
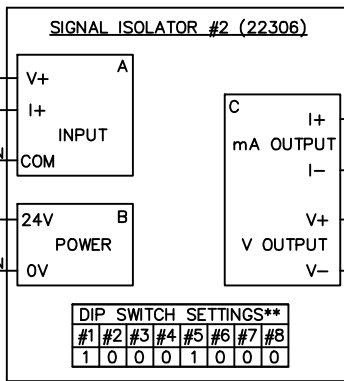
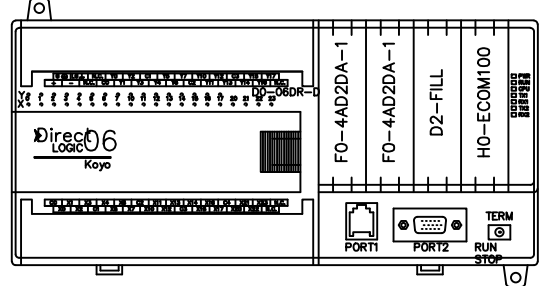
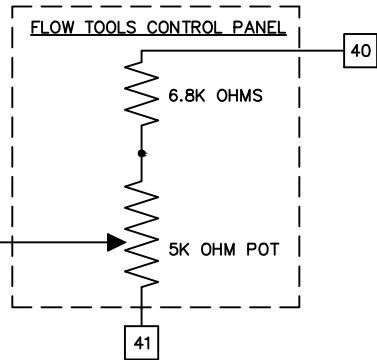
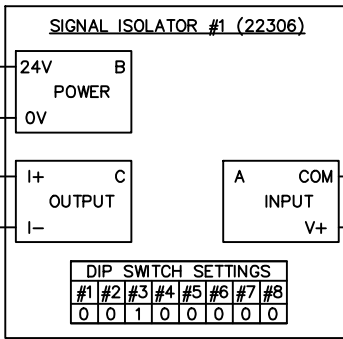

\* SPEED SIGNAL TO MODULE FEEDER CONTROL MUST BE INTERCEPTED BY THE MIRROR III IF FLOW TOOLS ARE TO BE USED.  
IF ORIGINAL MODULE FEEDER SPEED SIGNAL IS 0-20mA OR 4-20mA USE TERMINALS 90-93.  
IF ORIGINAL MODULE FEEDER SPEED SIGNAL IS 0-10V OR 0-5V USE TERMINALS 94-97.

\*\* DIP SWITCHS 5-8 ON SIGNAL ISOLATOR #2 MUST BE SET ACCORDING TO ORIGINAL SPEED SIGNAL TYPE. USE THE FOLLOWING TABLE TO DETERMINE THE PROPER DIP SWITCH SETTINGS.

SIGNAL TYPE	SW5	SW6	SW7	SW8
0-5V	1	1	0	1
0-10V	1	0	0	0
0-20mA	0	1	0	0
4-20mA	0	0	0	0

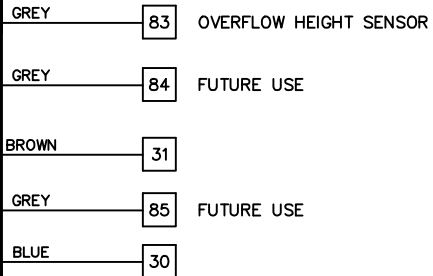
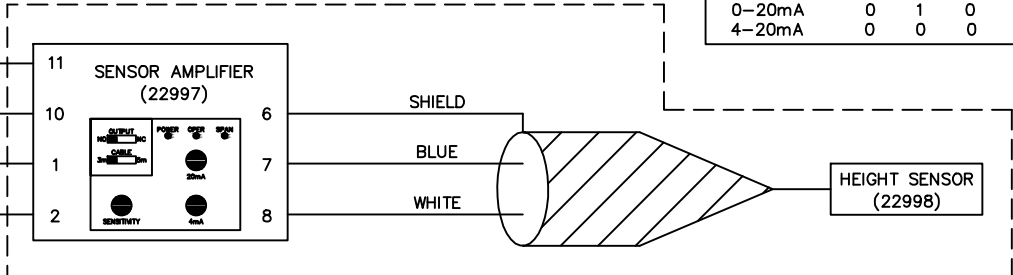

**SAMUEL JACKSON, INC.**

81890 FLOW TOOLS  
PLC WIRING DIAGRAM  
(ANALOG I/O)

CA20302B  
11-09